



INTEL

AMD

Dear customer,

Thank you very much for choosing the Noctua NH-U12A.

First introduced in 2005, our NH-U12 series has won more than 600 awards and recommendations from leading international hardware websites and magazines.

The NH-U12A is the latest addition to this prestigious series and I'm confident that you will be able to sense some of the research, attention and care we've put into making this product.

Enjoy your Noctua NH-U12A!

Yours sincerely,

Roland Mossig, Noctua CEO

This manual will guide you through the installation process of the SecuFirm2™ mounting system step by step.

Prior to installing the cooler, please consult the compatibility centre on our website ([ncc.noctua.at](http://ncc.noctua.at)) and verify that the cooler is fully compatible with your motherboard, CPU, RAM and case. Please also make sure that there are no compatibility issues with any other components.

Double check that the heatsink and fan clips do not make contact with the VGA card, other PCIe cards, motherboard heatsinks or any other components.

Noctua cannot be held responsible for any damage or losses caused by compatibility issues.

Should you encounter any difficulties, please check the FAQs on our website ([faq.noctua.at](http://faq.noctua.at)) and don't hesitate to contact our support team at [support@noctua.at](mailto:support@noctua.at).

Multilingual versions of this manual are available on our website: [www.noctua.at/manuals](http://www.noctua.at/manuals)

**INTEL** LGA1851, LGA1700, LGA1200 & LGA115x

**Required mounting parts:**

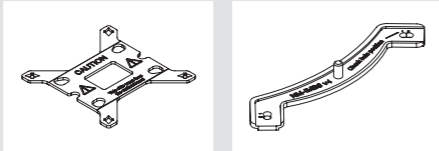

1x NM-IBP4 backplate

2x NM-IMB3 mounting bars



4x NM-ICS1 clip-on spacers

4x NM-ITS1 thumb screws

4x NM-IBT5 bolts



4x NM-IPS1 black plastic spacers for LGA1200/115x

4x NM-IPS3 blue plastic spacers for LGA1851/1700

**1 Removing the motherboard**

If you would like to use the cooler on an assembled system and your case does not have a cut-out at the rear side of the motherboard tray, you must first remove the motherboard from the case in order to be able to install the supplied backplate.

**2 Setting up the backplate**

First, identify the side of the backplate that should face the motherboard (marked with caution signs). Then choose the appropriate hole spacing for your socket and insert the four bolts into the backplate from the opposite side (marked with model name, SecuFirm2™ branding and numbers for hole spacing) at the appropriate position.

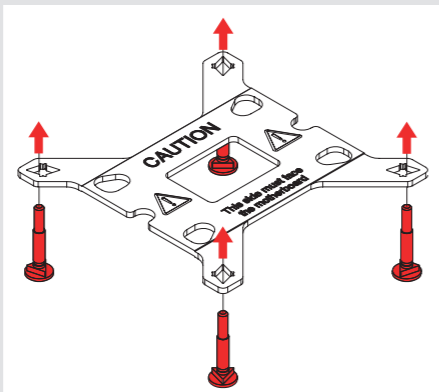

Use hole position 1 for LGA1200/LGA115x (LGA1150, LGA1151, LGA1155, LGA1156) and hole position 2 for LGA1851/LGA1700:

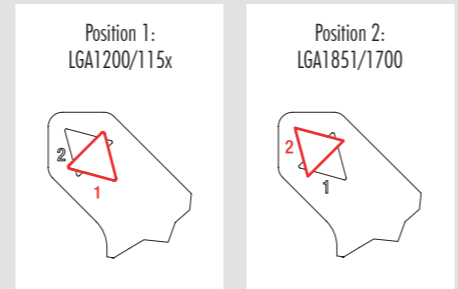

Fix the bolts using the NM-ICS1 clip-on spacers.

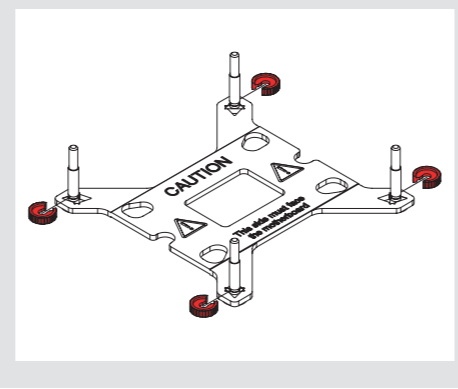

**3 Attaching the backplate**

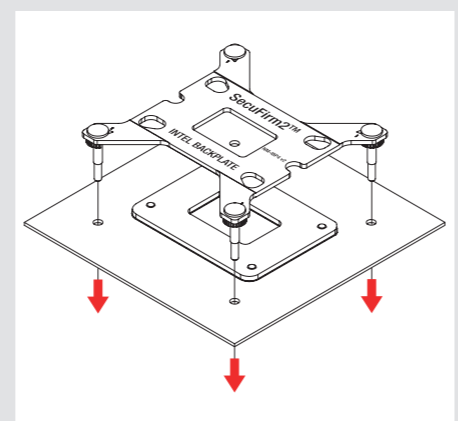

**Caution:** The supplied backplate will install over the motherboard's stock backplate, so the motherboard's stock backplate must not be taken off.

Place the backplate on the rear side of the motherboard so that the bolts protrude through the mounting holes.

**4 Installing the mounting bars**

Please first choose the correct set of plastic spacers and the correct set of holes on the mounting bars according to whether you are using an LGA1200/LGA115x (LGA1150, LGA1151, LGA1155, LGA1156) or an LGA1851/LGA1700 socket motherboard.

Use the black NM-IPS1 plastic spacers for LGA1200/LGA115x (LGA1150, LGA1151, LGA1155, LGA1156) and the blue NM-IPS3 spacers for LGA1851/LGA1700.

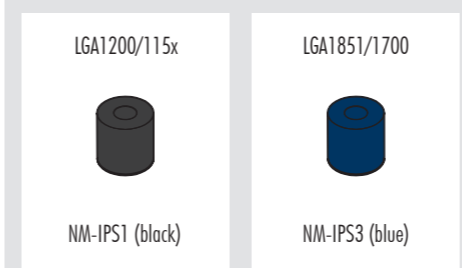

Use hole position 1 for LGA1200/LGA115x (LGA1150, LGA1151, LGA1155, LGA1156) and hole position 2 for LGA1851/LGA1700:

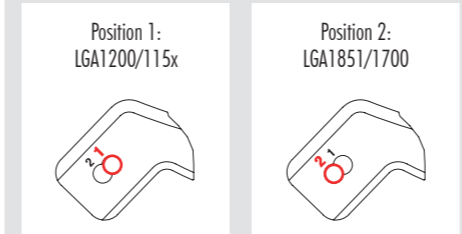

Put the plastic spacers onto the bolts of the backplate, then add the mounting bars.

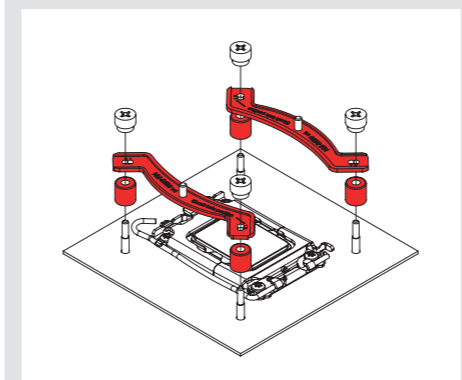

**Caution:** Choose the alignment of the mounting bars according to the desired final orientation of the cooler.

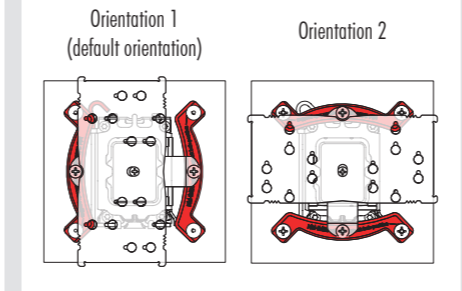

**Caution:** Make sure that the curved sides of the mounting bars are pointing outwards.

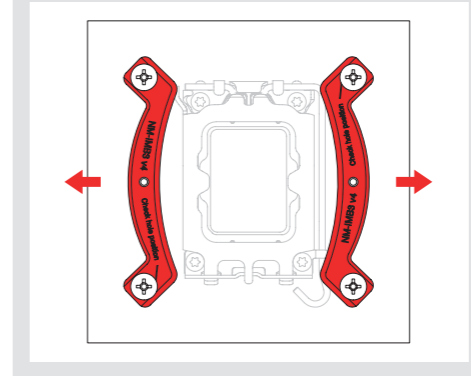

Fix the mounting bars using the four NM-ITS1 thumb screws.

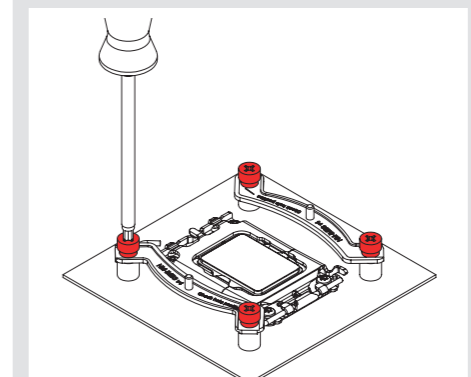

**Caution:** Gently tighten the screws until they stop, but do not use excessive force (max. torque 0.6 Nm).

**5 Applying the thermal paste**

If there are residual traces of thermal paste or thermal pads on your CPU, please clean them off first. Then apply the supplied NT-H1 thermal paste onto the CPU as shown in the following images.

For LGA1851/LGA1700, apply 5 small dots; 4 dots with ~2mm diameter near the corners plus 1 dot with 3-4mm diameter in the centre:

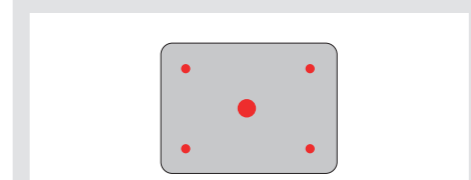

For LGA1200/LGA115x (LGA1150, LGA1151, LGA1155, LGA1156) apply a single 4-5mm dot in the centre:

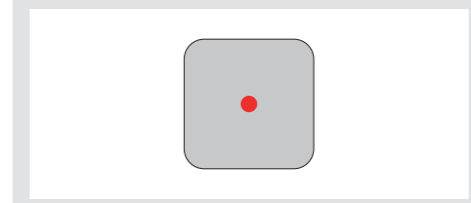

**Caution:** Applying too much thermal paste will lower heat conductivity and cooling performance!

**6 Fastening the heatsink to the CPU**

**Caution:** Please first take off the fans as well as the protection cover at the bottom side of the heatsink.

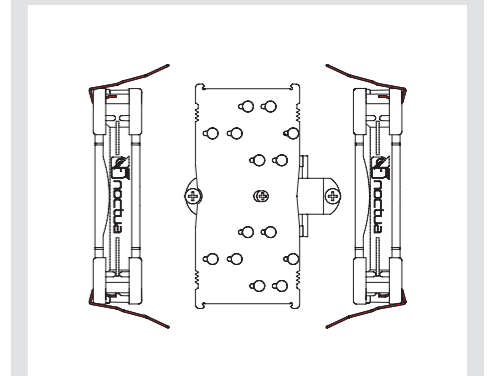

Then put the heatsink onto the CPU so that the longer side of the fastening bracket, marked in red, is positioned towards the RAM modules (default orientation).

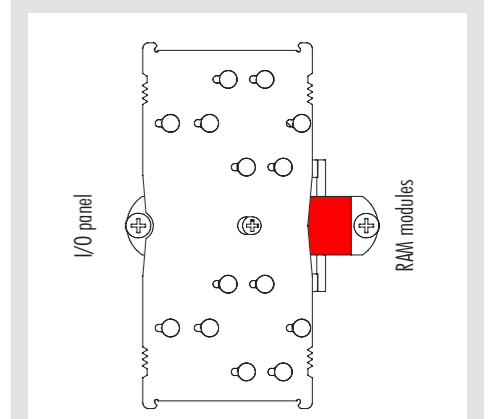

Screw the heatsink into the screw threads of the mounting bars by repeatedly performing 2-3 turns on each screw, until both are fully tightened.

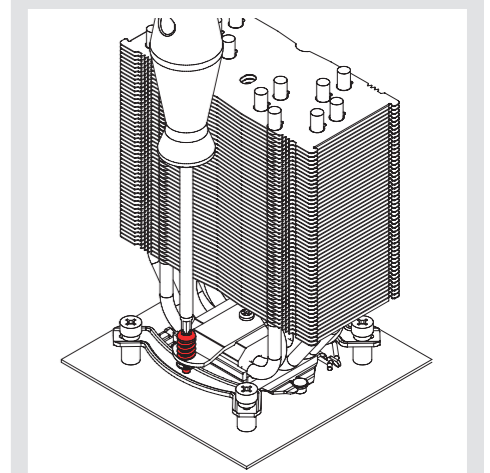

**Caution:** Gently tighten the screws until they stop, but do not use excessive force (max. torque 0.6 Nm).

## 7 Fan setup

Reattach both fans using the supplied steel clips for maximum cooling performance. Alternatively, you can leave the rear fan off and use it as a case fan instead.

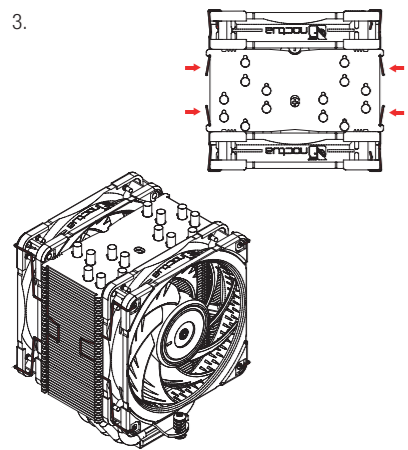
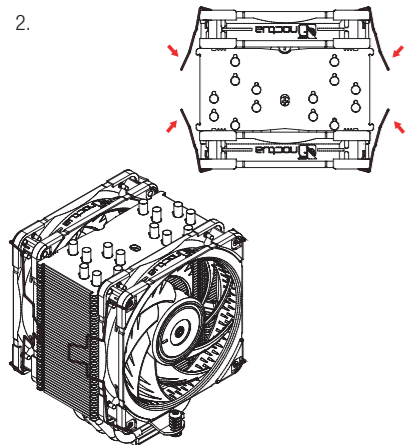
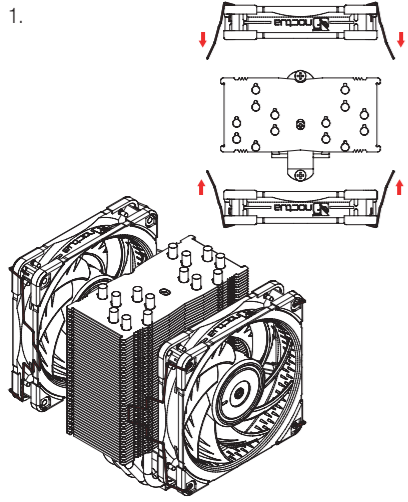

Connect the fan(s) to the motherboard's CPU fan header(s). If necessary, use the supplied NA-YC1 splitter cable to connect both fans to one fan header.

Depending on your CPU and the temperature inside the case, you may interconnect the supplied NA-RC14

Low-Noise Adaptor (L.N.A.) in order to further reduce the fans' operating noise.

**Caution:** Never use one adaptor for both fans by putting it before the splitter cable.

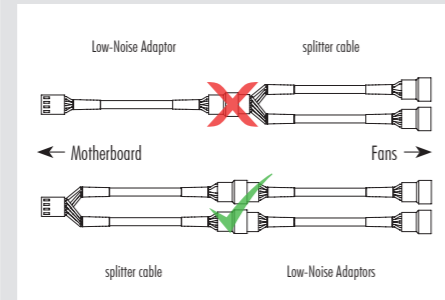

**Caution:** When using the L.N.A.s, check the temperature of your CPU using appropriate software (e.g. the respective applications of your motherboard manufacturer), in order to evade automatic throttling of the CPU due to the increased temperature. If the cooling performance is insufficient, please increase case ventilation or remove the L.N.A.s.

### ! Transporting your system

As it is not possible to reliably calculate or control the forces that act upon a system during transport (e.g. in shipping), we generally recommend, for safety reasons, taking the cooler off. Noctua cannot be held responsible for any damage that may arise due to excessive stress during transport if you keep the heatsink installed.

### ! Warranty, support and FAQs

Even with high-grade products and strict quality control, the possibility of defects cannot be eliminated entirely. Therefore, we aim at providing the highest possible level of reliability and convenience by offering a warranty period of 6 years and direct, fast and straightforward RMA service.

Should you encounter any problems with your NH-U12A, please don't hesitate to contact our support team ([support@noctua.at](mailto:support@noctua.at)).

Please also consult the FAQ section on our website: [faqs.noctua.at](https://www.noctua.at/faq)

## AMD AM5 & AM4

### Required mounting parts:

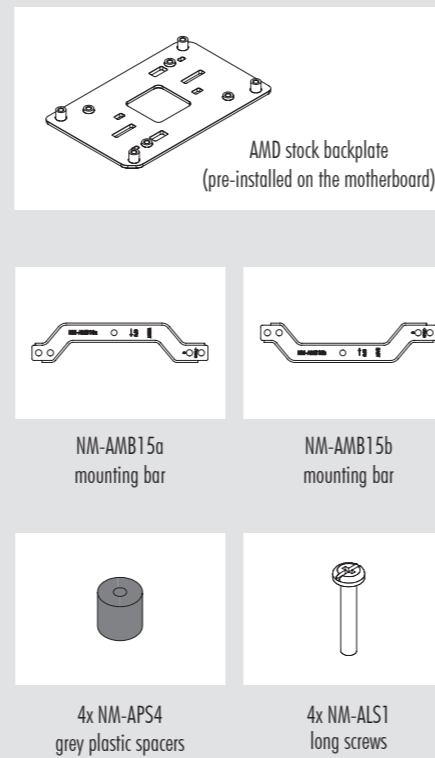

### 1 Removing the stock retention module — putting the backplate in place

The SecuFirm2™ mounting system will install directly to the motherboard's stock backplate, so please first remove the motherboard's stock CPU cooler retention module by unscrewing it from the backplate (if it has not already been removed for previous installations).

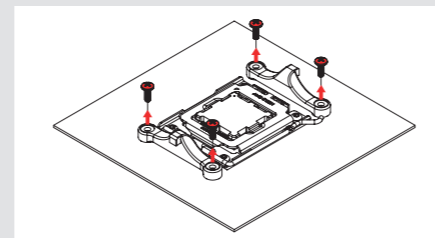

On AM4, the stock backplate will become loose when unscrewing the retention module, so hold it in place for the next step. If you have lost your stock AM4 backplate, please contact us at [support@noctua.at](mailto:support@noctua.at). On AM5, the stock backplate is screw-fixed to the socket, so should simply remain in place.

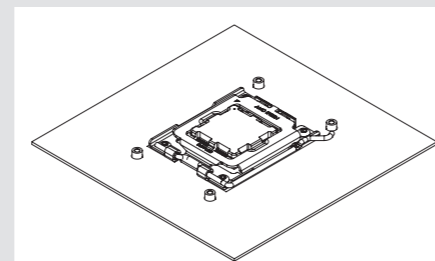

## 2 Installing the mounting bars

First put the plastic spacers onto the screw threads of the backplate. Then fix the NM-AMB15 mounting bars using the four NM-ALS1 long screws.

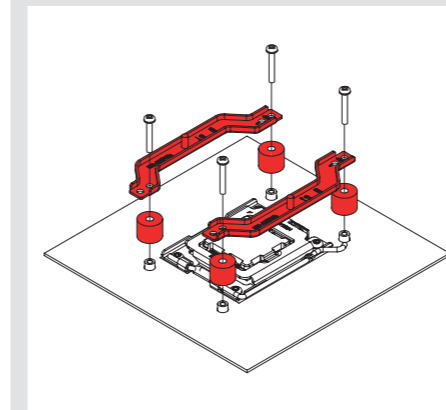

On AM5 and Ryzen 5000/3000 series AM4 CPUs, choose the -7mm offset hole position to ensure optimal contact quality and performance.

On other AM4 CPUs, or if there are any compatibility issues in the offset position (e.g. clearance with motherboard heatsinks), please choose the standard position (0).

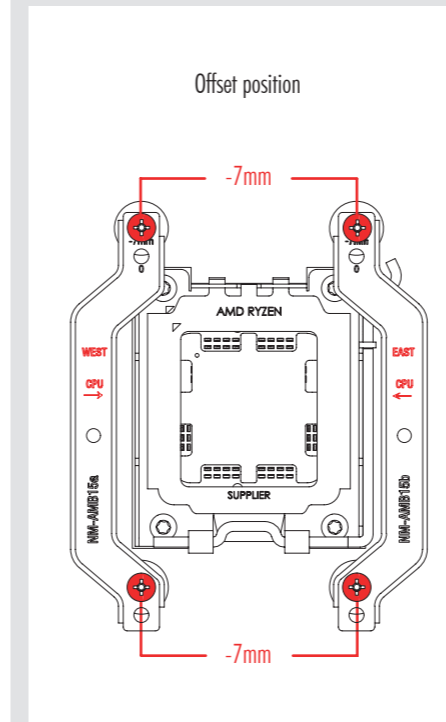
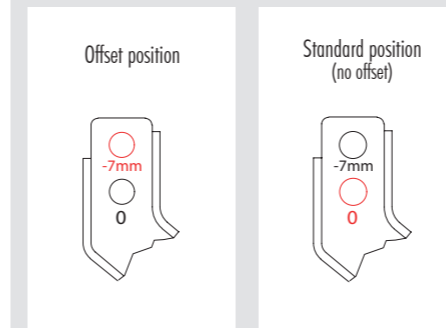

## 5 Fan setup

Please refer to step 7 of the Intel installation manual.

### ! Transporting your system

As it is not possible to reliably calculate or control the forces that act upon a system during transport (e.g. in shipping), we generally recommend, for safety reasons, taking the cooler off. Noctua cannot be held responsible for any damage that may arise due to excessive stress during transport if you keep the heatsink installed.

### ! Warranty, support and FAQs

Even with high-grade products and strict quality control, the possibility of defects cannot be eliminated entirely. Therefore, we aim at providing the highest possible level of reliability and convenience by offering a warranty period of 6 years and direct, fast and straightforward RMA service.

Should you encounter any problems with your NH-U12A, please don't hesitate to contact our support team ([support@noctua.at](mailto:support@noctua.at)).

Please also consult the FAQ section on our website: [faqs.noctua.at](https://www.noctua.at/faq)

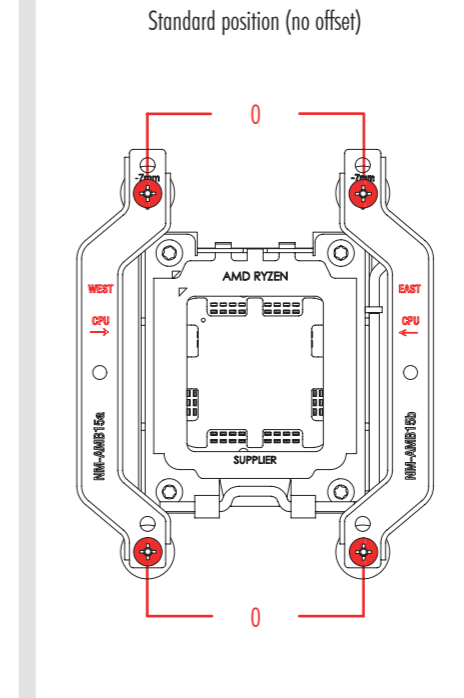

**Caution:** Make sure that the "CPU →" markings point towards the CPU and that the NM-AMB15a bar with the "WEST" marking is installed on the west (left) side of the socket and the NM-AMB15b bar with the "EAST" marking is installed on the east (right) side of the socket, as shown above.

Gently tighten the screws until they stop, but do not use excessive force (max. torque 0.6 Nm).

### 3 Applying the thermal paste

If there are residual traces of thermal paste or thermal pads on your CPU, please clean them off first.

Then, apply 5 dots of the supplied NT-H1 thermal paste; 4 small dots with ~2mm diameter near the corners plus 1 dot with 3-4mm diameter in the centre:

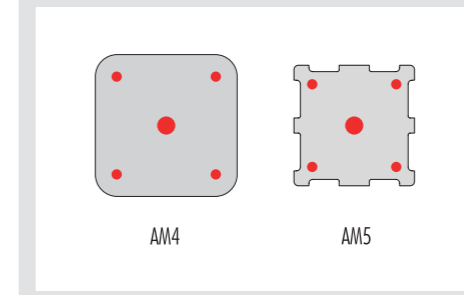

**Caution:** Applying too much thermal paste will lower heat conductivity and cooling performance!

### 4 Fastening the heatsink to the CPU

Please refer to step 6 of the Intel installation manual.